



Actual Size

DMS-EB

Multi-Purpose Application Board for DMS-30 & DMS-40 Series Meters

Order on-line at www.datel.com

Features

- Accommodates 3½ and 4½ digit meters
- Gain (span) and offset (zero) adjustments for DMS-30 meters
- Input divider network for high voltages
- Operate meter and board from +5V supply or 9/12V battery
- Solder gaps for decimal placement
- Same size as DMS-30/40 Series meters 2.02" (51.31mm)L x 0.83" (21.08mm)W

The DMS-EB Application Board covers many common panel meter applications while providing simple signal and power I/O terminations (via a standard MOLEX connector) for DATEL's DMS-30 and DMS-40 Series, LED/LCD Display, Digital Panel Voltmeters. The unique plug-and-play design of the DMS-EB makes changing from application to application and meter to meter quick, easy and inexpensive.

The highly versatile DMS-EB has provisions for such common applications as attenuation of high input voltages, gain (span) and offset (zero) adjustments, 9/12V battery operation, and direct decimal point placement. The DMS-EB is compatible with all four versions of the DMS-30 and DMS-40 Series ($\pm 200\text{mV}$, $\pm 2\text{V}$, $\pm 20\text{V}$ and $\pm 200\text{V}$) making it interchangeable from meter to meter and application to application. Solder gaps conveniently placed on the board are easily bridged or cut configuring the board to meet each application's specific requirements.

This low-cost addition to DATEL's expanding line of miniature meters is evidence of our continuing commitment to offer the most versatile, easy-to-use, panel meter products.

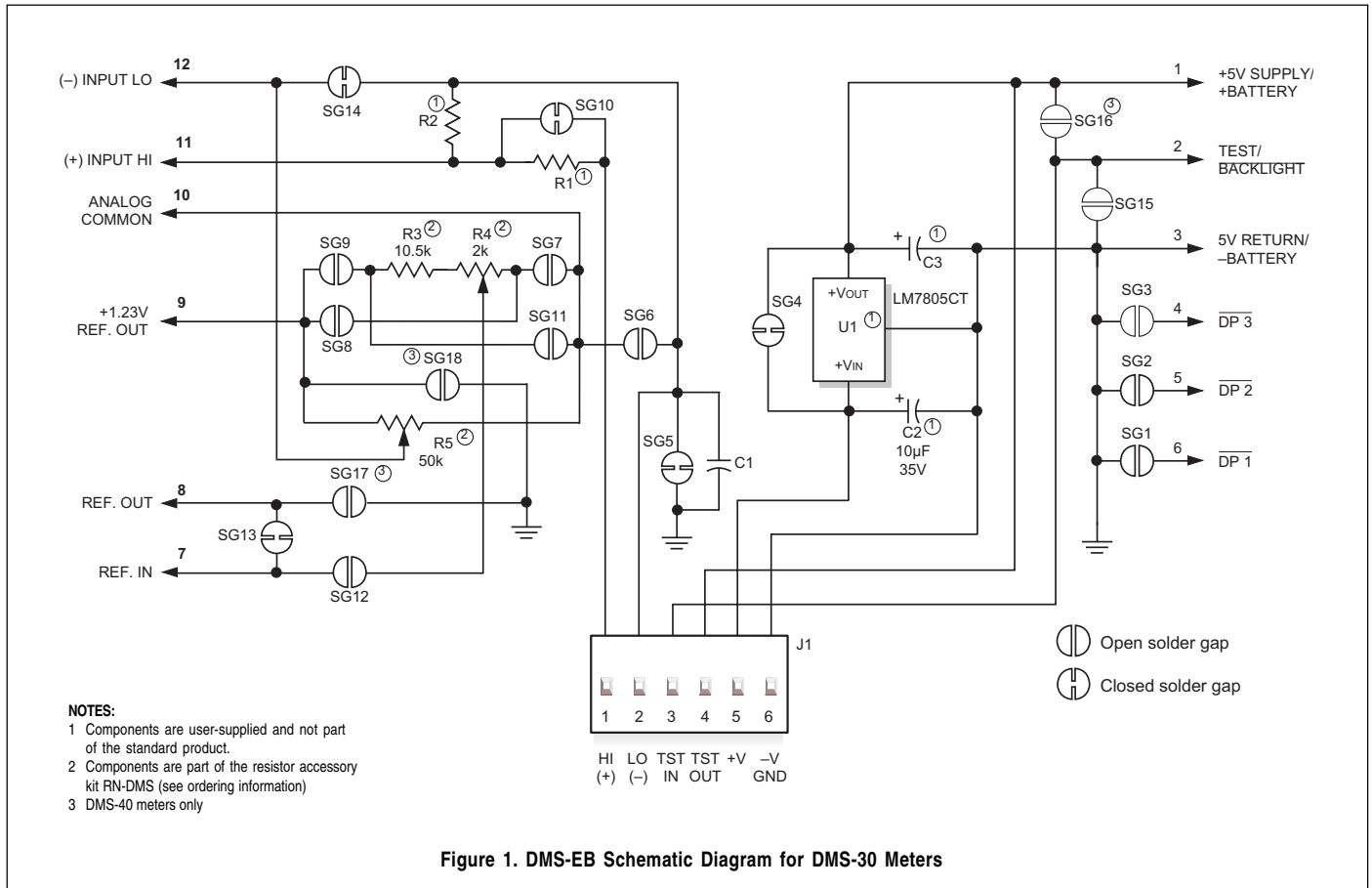

Functional Specifications (T_A = +25°C)**Input Supply Range**

See applicable meter's data sheet

Input Supply Range U1 (LM7805CT) Installed:

DMS-30/40PC-X-XS	+7.5 to +12.6V
DMS-30/40PC-X-XL	+7.5 to +18.0V
DMS-30/40LCD-X-5	+7.5 to +32.0V
DMS-30/40LCD-X-5B	+7.5 to +12.6V

Operating and Storage Temperature

See applicable meter's data sheet

Humidity

0 to 95%, non-condensing

Dimensions

2.02" (51.31mm)L x 0.83" (21.08mm)W

J1 Connector & Wire Information

Terminal Type	DATEL P/N 39-2099090
Crimp Tool	DATEL P/N 39-2099000
Wire Size	22 to 26 AWG
Insulation Diameter	0.062" (1.57mm) max.
Stripping Length	0.100" to 0.125" (2.54 to 3.17mm)

Ordering Information

DMS-EB	Application board with mating connector and terminals
DMS-BZL1	DMS-30/40 bezel assembly
DMS-BZL2	DMS-30/40 bezel assembly with sealing gasket
RN-DMS	Resistor accessory kit for DMS-30 meters
39-0304000	LM7805CT (U1), +5V-output, three-terminal regulator
39-2359625	6-position pc-board socket

Introduction

As shipped, the DMS-EB is configured for 5V-powered DMS-30 3½ digit meters operating in the single-ended mode (SG5 closed) using the meter's internal reference (SG13 closed). This configuration is the most common and works well for most simple voltage measurements.

Many of the applications described below apply to both DMS-30 and DMS-40 meters. However, Application 5, installing the span (R4) and offset (R5) adjust potentiometers, can only be used with DMS-30 meters. Also note that some of the other applications require the installation of R4 and R5. **See Technical Note 5 when using the DMS-EB with DMS-40 meters.**

Please read all of the following technical notes and perform any required modifications **before** soldering the DMS-EB onto the meter (aligning pin 1 to pin 1). After soldering, carefully connect +5Vdc to +V (J1, pin 5) and power return to -V (J1, pin 6).

Technical Notes

- 1. LCD Backlighting:** For DMS-30LCD backlit models, close SG15. For DMS-40LCD backlit models close SG18. See the DMS-30LCD or the DMS-40LCD data sheets for limitations on backlighting 9V-powered meters.
- 2. 9V-Powered, LCD Display Models:** DMS-30LCD-X-9 and DMS-40LCD-X/X-9 meters **cannot** be used in single-ended input configura-

tions, i.e., LO (J1, pin 2) cannot be connected to GND (J1, pin 6). When operating from a 7.5 to 14Vdc power source with a single-ended input, use a +5V-powered meter and install U1 (see Battery Operation section and Technical Note 4).

Close SG6 when measuring floating inputs with a 9V-powered meter (floating inputs are described in Technical Note 7). SG6 provides a bias reference for the input signal by tying LO to the meter's Analog Common terminal (pin 10).

- 3. Input Resistor Dividers:** Use 1%, or better, metal film resistors for R1 and R2 in DMS-30 applications, and 0.5%, or better, in DMS-40 applications. Using tight-tolerance resistors in input divider networks allows most final calibration adjustments to be made with the meter's rear calibration pots through the access holes provided. Make sure the resistor power and voltage ratings are adequate for the given application.
- 4. Using U1 (LM7805CT):** The power supply voltage range listed in the Battery Operation section is rated for a 150mA LED meter or a 35mA backlit LCD meter. A 10µF/35V tantalum capacitor (C2) should be installed with the polarized end next to the + symbol on the DMS-EB. This is especially important if the power supply is located far from U1.
- 5. DMS-40 Meters:** When the DMS-EB is used with DMS-40PC or DMS-40LCD meters, be sure to open SG13. The RN-DMS resistor accessory kit comprised of resistor R3 and potentiometers R4 (Gain/Span) and R5 (Offset/Zero), **cannot** be used with DMS-40 series meters. To change the input range on DMS-40LCD meters from the low range to the high range, close SG16.
- 6. Calibration Potentiometer Adjustment Holes:** Two overlapping holes on the DMS-EB provide access to the ¼-turn calibration potentiometer on DMS-30 meters and the 3-turn potentiometer on DMS-40 meters. The adjustment range of both pots is very narrow. See the applicable product data sheet for more information on each meter's calibration potentiometers.
- 7. Input Configurations:** The DMS-EB is supplied with SG5 closed. SG5 connects J1, pin 2 (LO) to power return J1, pin 6 (GND) and configures the meter for single-ended operation, that is, the low side of the input is at system ground or zero Volts. SG5 must also be closed when measuring floating inputs. Floating inputs are signals which have no electrical connection, or reference to, the power supply which powers the meter.

In applications in which input LO is connected to ground elsewhere in the system, and SG5 is closed, unwanted ground-loop induced display errors may develop. Ground loops, a condition in which display drive currents also flow through the input signal wiring, can cause unstable display readings. If this occurs, try opening SG5 to see if the display stabilizes.

SG5 must be open when measuring differential inputs that are referenced to the same supply which powers the meter. DMS Application Note 2 (Input Configurations, Power Supplies and Ground Loops) provides a detailed discussion of input configurations.

- 8. Soldering:** DATEL recommends the use of "no-clean" solders when installing or making modifications to the DMS-EB.

Applications

- 1. Decimal Point Placement:** DATEL ships the DMS-EB with all decimal point solder gaps (SG1, SG2, SG3 and SG17) open. To enable a specific decimal point, close its respective solder gap with solder. When reassigning decimal places for subsequent applications, remember to open previously closed solder gaps.

- Close SG1 for 1.999 (DP1)
- Close SG2 for 19.99 (DP2)
- Close SG3 for 199.9 (DP3)
- Close SG17 for 1999.9 (DP4 on DMS-40)

- 2. Display Test:** Tie J1, pin 4 (TEST OUT) to pin 3 (TEST IN) to test the display of the DMS-30. Do not leave the meter in the test mode for more than 10 seconds. Display test is not available on backlit models

- 3. Battery Operation:** Do not use this feature with blue LED meters. Open SG4 and install U1 (LM7805CT) with its metal tab facing down as shown Figure 2. Allowable input power ranges (J1, pins 5 and 6) are as follows:

DMS-30/40PC-X-XS	+7.5 to +12.6V
DMS-30/40PC-X-XL	+7.5 to +18.0V
DMS-30/40LCD-X-5	+7.5 to +32.0V
DMS-30/40LCD-X-5B	+7.5 to +12.6V

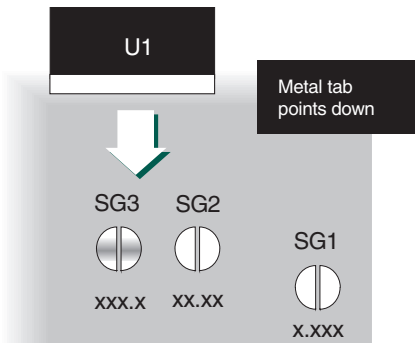

Figure 2. Installing U1

- 4. Differential Input Signals (Signal Referenced to Power Source):** Open SG5. Apply the input signal to pin 1, (+) IN HI, and pin 2, (-) IN LO, of J1.

Note: Common mode voltage must not exceed ±2Vdc. Differential signals are defined as inputs whose two terminals are both above and below J1, pin 6 (GROUND).

- 5. Span (Gain) and Zero (Offset) Adjustments:** DATEL offers a resistor accessory kit consisting of resistor R3 and potentiometers R4 and R5. Once installed, these components

permit the span and zero adjustments described in the following sections. R3 and R4 provide span adjust while R5 applies an offset to (-) IN LO (J1, pin 2).

Using Full Range Span Adjustment (DMS-30 Only)

- For DMS-30-1 and -2 models: Configuring the DMS-EB for span adjustment is simply a matter of installing resistor R3 and potentiometer R4, opening SG13 and then closing SG8, SG11 and SG12.
- For DMS-30-0 models: Span adjustment requires that you open SG8, SG11 (if closed) and SG13 and then close SG7, SG9 and SG12. Then install R3 and R4.

Adjust span as desired. DMS-30-1 and -2 span adjustment range is typically +10% and -5%. The DMS-30-0 has a much wider span adjust, however, it should be limited to ±10% for optimum accuracy.

- 6. Measuring Input Voltages Greater than 1.999Vdc (Use DMS-30-1 Only):** If possible, the resistors used for R1 and R2 should be ±1% metal-film types with TCR's less than 100ppm/°C. More information on selecting 1% resistors can be found in Application Note 14 of the DATEL Panel Meter Catalog.

CAUTION: Do not exceed 250Vdc input signals.

- Open SG10. For applications in which input voltages exceed ±100Vdc, also cut the 2 adjoining traces.
- Configure the DMS-EB for span adjust using the procedure previously outlined for the DMS-30-1 version.
- Calculate values for R1 and R2 as follows:

A typical value for R1 is 1MΩ. The sum of R1 + R2 should be between 50kΩ and 10MΩ

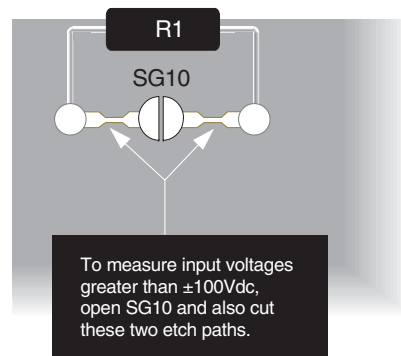

Figure 3. Installing R1

$$R2 = (FSI \times R1) / (|V_{IN}| - FSI)$$

Where:

FSI = The attenuated voltage, between the meter's (-) IN LO and (+) IN HI pins, needed to achieve the desired display readings

V_{IN} = Input voltage at J1 (between pins 1 and 2)

Applications

Example

V_{IN} is 0-5Vdc, and the display reading must be "000" to "1500".

- Assume $R1 = 1.0M\Omega$
- $R2 = (FSI \times R1) / (|V_{IN}| - FSI)$
 $R2 = (1.500 \times 1,000,000) / (5.0 - 1.500)$
 $R2 = 428,571\Omega$ or $432k\Omega$
- Calibrate the meter using a known voltage source. Adjust R4 to compensate for variations in R1 and R2.
- Current Measurements** (Use 200mV Model, DMS-30-0): The following instructions are for measuring current derived from the DMS-30/40's power source. When measuring current that is floating with respect to J1, pin 6 (POWER RETURN), leave SG5 closed.

CAUTION: Do not exceed 1 Ampere input current

- Install R2: $R2 = FSR / (I_{MAX} \times 10000)$ where FSR is the desired meter reading (0 - 1999) and I_{MAX} is between 0 - 1 Ampere.

- Open SG5.
- Configure the DMS-EB for span adjust using the procedure previously outlined for the DMS-30-0 version.
- Apply input signal (current) to (+) IN HI and (-) IN LO.
- Adjust R4 for desired full scale readings.
- Enable the appropriate decimal point using either SG1, SG2, SG3 or SG-18.

Example

A 0.100 Ampere input must read "100.0" on the display.

$$R2 = 1000 / (0.1 \times 10000)$$

$$R2 = 1 \text{ Ohm}$$

Enable DP3 via SG3 for a reading of "100.0".

DMS-EB Board

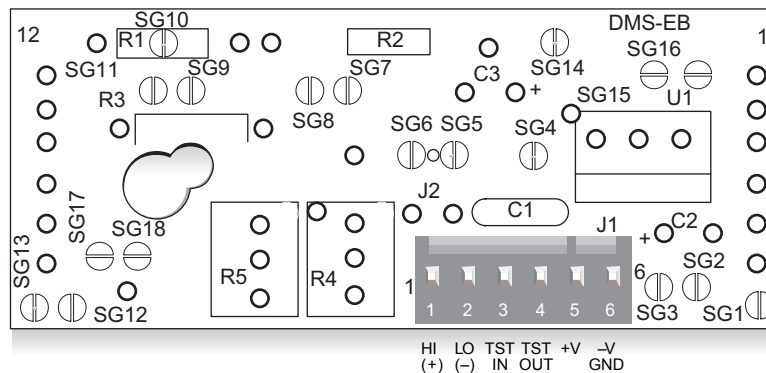

Figure 3. DMS-EB Board